

LUXURY
PERFORMANCE CRUISER

50



2024



Arcona
yachts

"The ability of the boat to harness light- to mid-strength winds also stood out. During our second sail...with the foot of that big blue gennaker skirting the water, we almost matched the 10 knot true wind."

- **Toby Hodges, Yachting World**



ARCONA'S STORY

It is a fantastic feeling when you set sail, start to trim, and feel the drive in the boat. When she gets a touch of heel and takes off, you feel the balance and stiffness, that is unbeatable. That's world class.

An Arcona is a collaboration of ideas that we get, as sailors, who sail the yachts. We realise when the reach for the wheel is a bit too far, then we make an adjustment. We understand where we need an extra foot support or how to make it easier to reach a winch. We are as much sailors as yacht manufacturers.

The DNA for Arcona Yachts is really the perfection of the performance cruiser concept. A yacht that performs well, as well as being comfortable and safe to cruise. Every Arcona model is designed and built to be easy to sail and manage by two people in any situation.

We have been building performance cruising yachts since 1982. Now we proudly present the Arcona 50 luxury performance cruiser, designed by Jeppesen & Pons.

"The Arcona 50 provides an impressive example of its capabilities in all conditions. The powerful hull design from Jeppesen & Pons with the wide stern offers noticeably high stability. The boat sails stiff and upright, which is particularly pleasant on the long courses. Equipped with the optional overlapping genoa with genoa sheet tracks on the coachroof, the Swede also sails very well upwind."

"What's also surprising is how agile the stylish boat performs and how quickly it returns to the target boat speed after manoeuvres."

- Michael Good, Yacht Germany



SWEDISH QUALITY

The production process of a new boat poses thousands of different questions and complex decisions; the selection of materials, the specification of the fittings, the choice of running and standing rigging, to name but a few. The solution is to precisely tailor each decision to meet the high standards we have set to achieve owner expectations. It is a challenging and rewarding process, yet straightforward – quite simply, we want to build you a boat that we can be proud of and that you will love.

The hull is built to be stiff and strong, ensuring the boat can always be sailed safely. Swedish heritage flows through the build, design and lines of our yachts. Arcona yachts are bright, beautiful and functional with many hidden qualities – qualities which you will appreciate more and more with each passing year of ownership of your Arcona 50.



THE DESIGNERS JEPPESEN & PONS

With over 6000 yachts on the water and a race-winning pedigree, Principal Designer, Niels Jeppesen and Yacht Designer & Naval Architect, Ariadna Pons, bring a wealth of experience to Arcona Yachts.

Niels' yacht designs have had the most prestigious race victories. They have won $\frac{3}{4}$ Ton Cup world championships six times and the One Ton Cup twice & became best Two Ton yacht at the Admiral's Cup 1989. Three yachts designed by Niels won the Commodores Cup (France Team), Sardinia Cup and SORC (USA) also had his designs at the top. After 2000, yacht models by Niels came top at the ORC Worlds several times.

Ariadna studied Naval Architecture and Marine Engineering at Universitat Politècnica de Catalunya, Barcelona, just before undertaking her Masters in Naval Architecture at the University of Southampton.

After working together with Niels Jeppesen at X-Yachts, they joined forces to create the Naval Architecture Studio, Jeppesen & Pons.

As the first Arcona model to be designed by Jeppesen & Pons, Arcona challenged them to design an aesthetically pleasing and functional yacht in both the interior and exterior spaces. To obtain the ambitious goal of cruising and performance, intelligent design and advanced build technology, resources have been applied, establishing a new and clear distinction compared to the previous designs found on the market.

The new Arcona 50 is the perfect blend of Scandinavian design and Swedish build quality.

THE ARCONA 50

The new Arcona 50 is highly versatile. At Arcona we take extra measures to build a strong and safe, high quality performance cruiser yacht that will last. You can expect the highest standards of Swedish workmanship, strength, and safety in every aspect of the yacht. Wherever possible we have optimised materials and components to save weight, maintain structural integrity and strength to create pure sailing performance. Numerous design aspects make the Arcona 50 a pleasure to sail shorthanded for the active cruising couple, while still offering well thought-out solutions and functional space for family and friends.

She has a three-spreader mast with discontinuous rod rigging and a high aspect ratio sail plan. The yacht can be configured to your specific needs with a range of options from high spec sail handling and trimming to push-button sailing for a relaxed cruise with the family.

Given the nature of long-distance cruising it is completely understandable that you will choose to add a dishwasher, washing machine, your bikes, etc. To anticipate this, we have specified the most weight-efficient items without compromising on quality.

The Arcona 50 sleeps six people in three cabins. Going below, you are welcomed by natural light from the hull windows into a bright, well-ventilated interior with plenty of headroom. Modern Scandinavian design elements are brought to life with handcrafted, top-quality woodwork in the best of Swedish boatbuilding traditions. Beautifully varnished surfaces with rounded edges for comfort and safety in a seaway and with sturdy handholds just where you would expect them to be. Superyacht sound insulation in the engine compartment...and so many more thoughtful details to ensure maximum performance cruising pleasure.

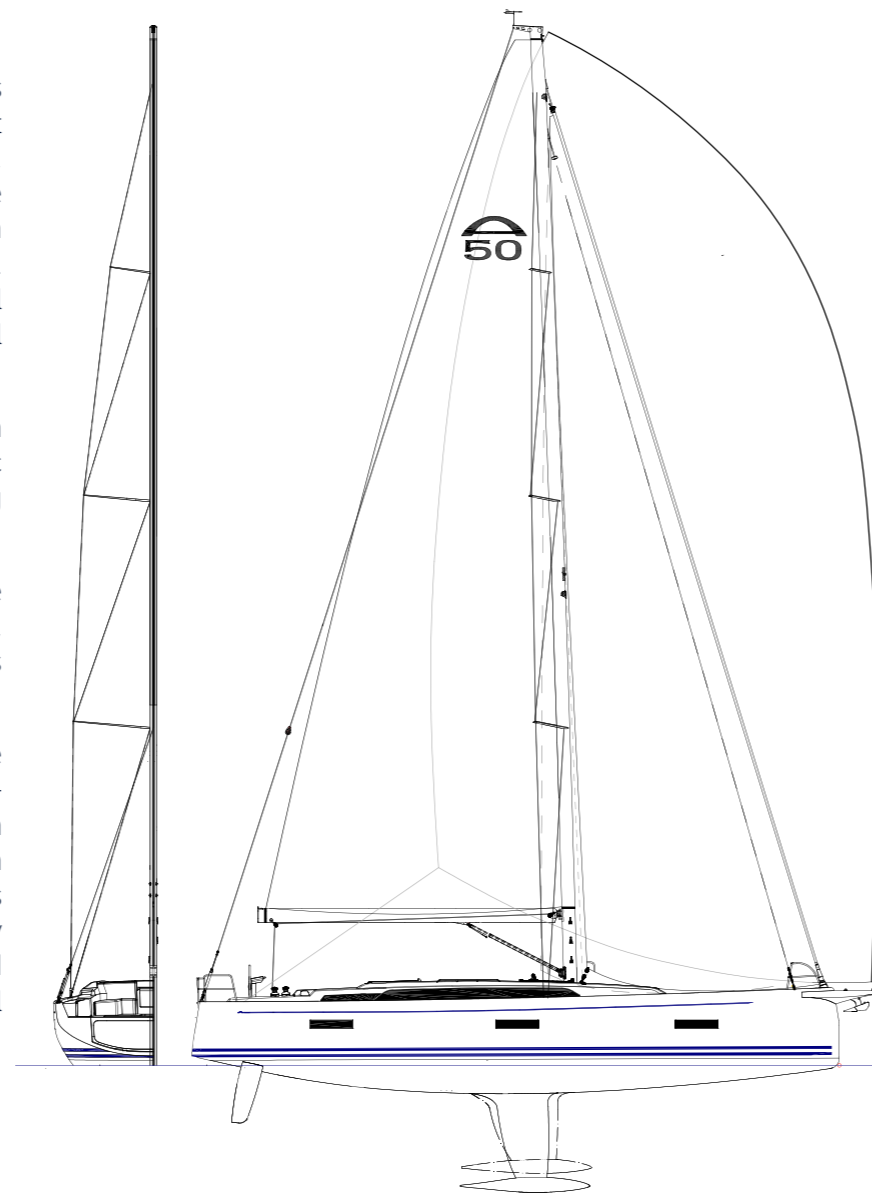

"The Arcona 50 is fast to find its groove and boasts plenty of grip..."
- *Toby Hodges, Yachting World*

EXTERIOR DESIGN

HULL

The aesthetic 'expression' of the Arcona 50 is designed to give the feel of elegance and strength. The side profile bow 'knuckle' at half height freeboard flows through the Bmax to the transom's soft chine, inspired by the latest IMOCA and America's Cup yachts.

Compared to other designs on the market, Jeppesen & Pons have managed to save approximately 5% in overall weight, which is why the Arcona 50 can deliver outstanding sailing performance even as a luxury cruising yacht.

The hull design has a lighter volume of displacement especially in the aft part of the hull where the water flow has a flatter exit, securing a higher hull speed.



KEEL

The Arcona 50 keel's fins are made of the best Swedish quality cast iron, which allows the fin geometry to be optimised and therefore the lead bulb to be heavier - increasing the stability and therefore providing better boat performance. The fin sections are also optimised which reduces resistance by having less wet surface.

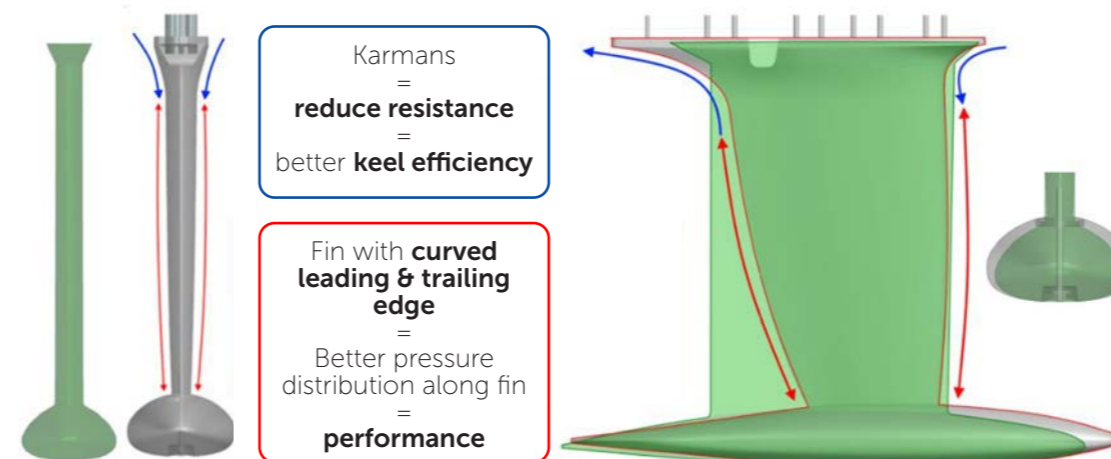

GREEN - Typical production yacht keel design
GREY - Arcona 50 optimised design

KEEL OPTIONS

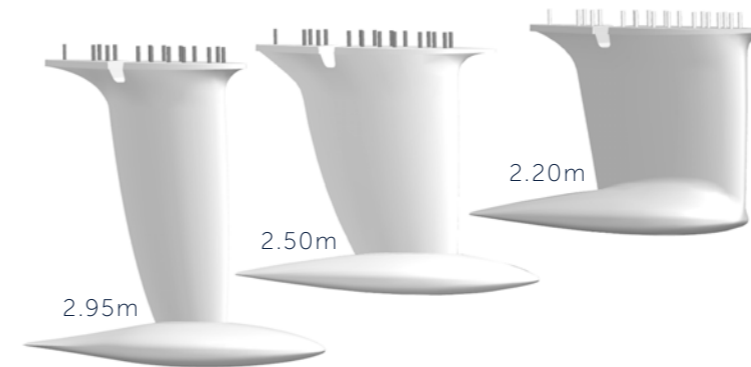

BOWSPRIT

The design and position of the Arcona 50 (optional) bowsprit is also different from the mainstream, with roots in TP52 and similar racing boats. Aesthetically it lowers the height of the bow profile - increasing the area of the kite/Code Zero.



EXTERIOR DESIGN

The Arcona 50 is ideal for safe and comfortable long distance performance cruising. The twin rudders with independent steering systems on separate quadrants, provide more control in the water and can be upgraded to carbon. Under sail she is superbly balanced and responsive to the helm. Her uncluttered decks and flush hatches ensure movement around the boat can be made with ease.

- 1.** The anchor chain compartment is located aftmost in the sail cabin, minimising the pitching moment whilst going upwind, for improved performance and comfort.
- 2.** Self-tacking jib track, located on the top of the coachroof, operates either the furling jib or an optional heavy weather jib.

3. Optional longitudinal Genoa sheet tracks, sheets run below deck to cockpit winches.

4. Large hinged sprayhood is housed in a below deck self-draining coachroof storage.

5. Cockpit layout with 2 L-shaped side benches, for 2 cockpit tables, enables comfortable movement from aft cockpit to companionway.

6. Main sheeting via a cockpit floor recessed single block (housed in a self-draining compartment). Traveller (optional).

7. There is a self-draining halyard/sheet compartment under the side deck to secure a clean and tidy cockpit.

8. Back stay chainplate is designed also to work as a mooring guide (mooring line has padded location protection).

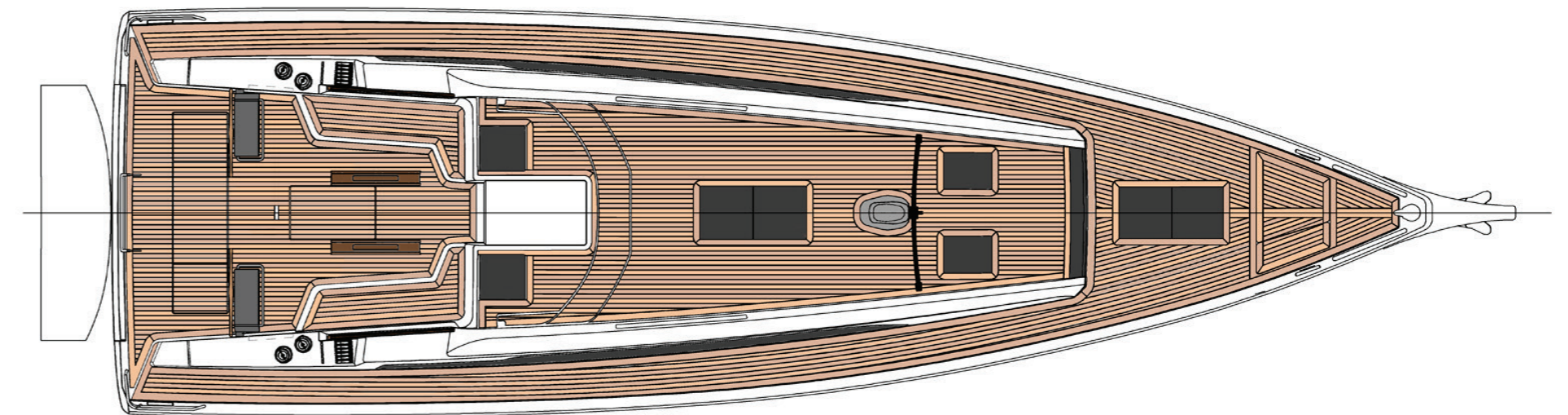

EXTERIOR DESIGN

The cockpit area is cleverly designed to be both functional and comfortable. The L-shaped cockpit benches and the two drop-leaf cockpit tables enable guests and crew to move around the cockpit more easily under sail and provide a superb space for al fresco dining at anchor.

1. The height of the bulwark is increased by about 50% to maximise safety for crew.

2. Aft side deck compartment, to port for gas bottles, to starboard for shorepower socket and cable storage.

3. Central pushpit design, which integrates an option for a hinged 2-seater teak bench/backrest.

4. Dinghy garage (with LED lighting) accommodates a fully inflated dinghy. Transom door operated with two electrical LINAK® actuators, controlled by a switch in the cockpit coaming. Dinghy garage/Transom door, finished in Flexiteek, doubles up to be a bathing platform.

5. Cockpit floor self-draining compartment with space for max. 8-person life raft.

6. Optional main sheet traveller, electrically operated via a cockpit floor recessed track system.

7. The increased bulwark height also enables underdeck passage of the (optional) bowsprit's 'tack line' and the head stay's furler line. These lines are operated by port cockpit winches.

8. Cockpit coaming height/side bench backrest height is higher and more comfortable than other comparable yachts. The addition of a teak fiddle also works as a handhold and anchoring points for the sprayhood when it's up.





"The high-quality construction creates peace and stability. Below deck, one thing is particularly noticeable: the peace and quiet on the move and during manoeuvres. This is due to the perfect insulation...but also to the first-class workmanship and the high-quality construction of the hull and deck."

- Michael Good, Yacht Germany

INTERIOR DESIGN



1. Standard layout: with 3 double cabins, parallel galley and L shape sofa. With the freeboard facing chart table there is space for a separate shower area in the heads.



2. Optional layout: with U-shape galley, U-shape sofa, twin aft berths & forward facing chart table.

Below deck minimalist Scandinavian elegance permeates every detail. The interior is made in Khaya Mahogany and can be upgraded to Light Oak. As seen in superyachts, a large proportion of the interior's woodwork is cored to maximise weight saving without compromising on strength or on the aesthetics. The Arcona 50 saves approx. 800kg compared to traditional interior manufacturing.

The galley has lots of practical stowage, a gimballed cooker with oven and a generously-sized sink and fridge. The standard layout allows for easy access to the L-shaped saloon seating. There is the option to have U-shaped seating and additional galley workspace too.

The saloon table has an additional seat/coffee table to starboard that can be moved and locked into position.

The owners cabin features a kingsize bed, generous storage and an en-suite with separate shower.

For guests the two aft cabins are doubles as standard or you can choose to have a convertible modular twin configuration with an infiller.

LED lighting (reading lights, overhead dome lights and various ambient lighting controlled by dimmer switches), is standard in all cabins, the saloon and galley.

A variety of option combinations are available. To personalise your Arcona 50, please contact us or see the Arcona 50 configurator on arconayachts.se.

INTERIOR DESIGN

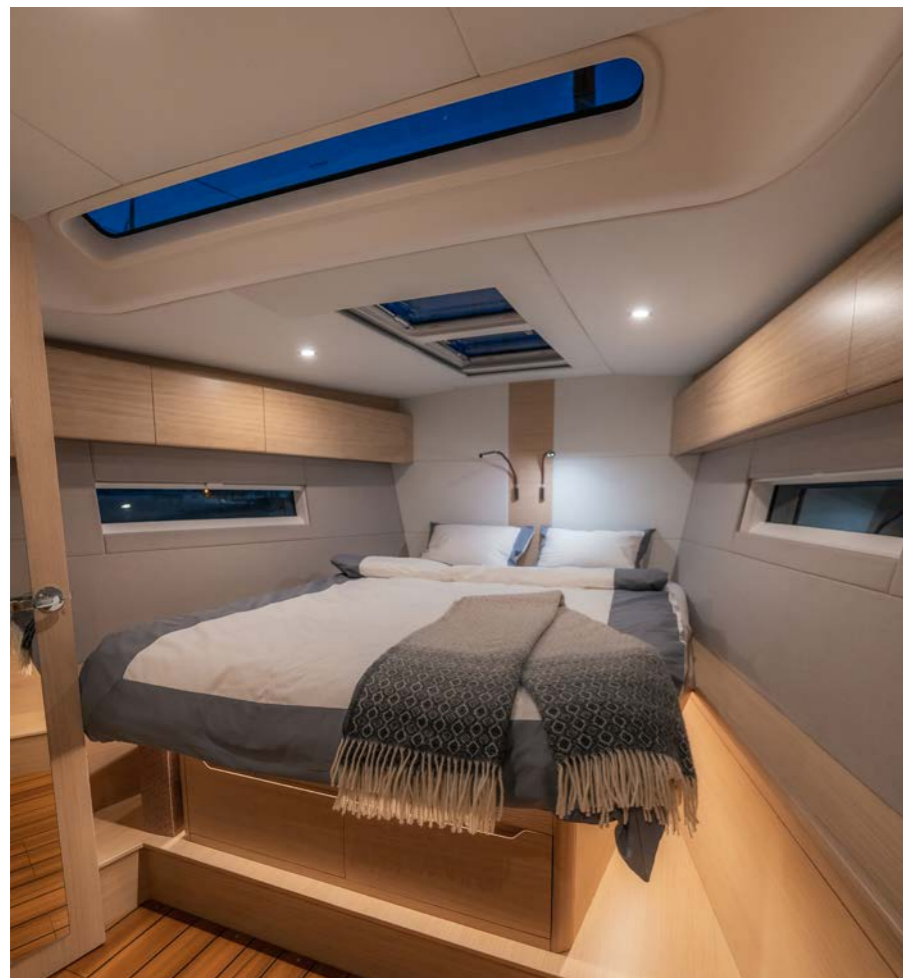

Luxurious owners' cabin with a double berth, superb storage and an en suite with separate shower.



Both aft cabins have double berths as standard. There is an option to have twin berths (with in-fill cushions to convert twin to double when required).

The Arcona 50 is designed to be sailed for extended periods of time and in any weather, so a comfortable relaxing yacht interior is an important attribute.

We have selected high quality interior materials, integrated technology & equipment and practical features to ensure that you enjoy all aspects of your yacht for a truly luxurious entertaining and living spaces.

We offer a broad range of cushion fabrics and colour choices and you make that selection when you order your Arcona.

All cabins are equipped with roof lamps and two bulkhead-mounted reading lamps with charging ports.

Deep book shelves and top cupboards line the saloon for maximum storage. Entertainment systems are integrated, with a saloon TV and audio running throughout the boat.

Attention to detail is core to the handcrafted high quality finish of every Arcona. From the wardrobes in the cabins, to the rounded corners of the woodwork throughout the yacht, to make life onboard a pleasure.

A true luxury performance cruiser, equipped to take you anywhere safely and in comfort.



TECHNICAL DATA

Design:	Jeppesen & Pons
CE Category:	A-Ocean
Length Overall including optional bowsprit:	15.80m
Length Overall:	14.99m
Length Waterline:	13.98m
Beam:	4.60m
Draft:	2.95m/2.5m/2.2m
Displacement:	13900/14500/15300kg
Mast Height:	24.08m
Engine:	Yanmar 4JH80CR
Saildrive:	SD60

TANKS

Fuel:	385L
Water Capacity:	375L
Hot Water:	40L

*+125L optional extra on water or fuel

SAIL AREA

Main Sail:	86m²
Self-tacking Jib:	56m²
Overlapping Jib	
110% (Option):	65m²
Asymmetric Spinnaker:	222m²

RIG DIMENSIONS

I:	21.00m
J:	5.74m
P:	20.10m
E:	6.85m

SUPPLIERS

Another essential piece of the puzzle for Arcona Yachts is to install good quality gear. Therefore, we choose companies that care as much about their products as we do for our yachts. We take no shortcuts and all our partners are carefully selected. With a long history as boat builders, the partnership with our suppliers is a relationship that has grown and developed as the company has evolved. The brands we are working with today are the best in the industry regarding quality, guarantees and customer support.



PEACE OF MIND

Safety and quality mean different things to different people. For Arcona it means paying attention to the things we know offshore sailors will appreciate, like watertight bulkheads fore and aft; a galvanised high-strength steel structure that reinforces the hull and joins mast and keel in the strongest possible manner; twin rudders with independent steering systems on separate quadrants; gelcoat that meets the toughest requirements.

HULL & DECK

Vacuum infused sandwich construction using Divinycell foam cored multi axial E-fibres and carbon fibres reinforced with vinylester for strength, stiffness and low weight. Local areas for hull skin passages such as for the rudder bearings, through hull fittings, depth and speed transducers, keel attachment and fixing points for chainplates are solid laminate. Local areas for the winches, hatches, clutches, etc., reinforced using unidirectional E-Glass, and replacing the foam core with composite or aluminium, depending on application.

BULKHEADS

Composite vacuum infused E-glass ringframes and bulkheads for the main bulkhead, the bulkheads towards sail locker and the bulkhead towards the lazarette. The composite bulkheads towards the sail locker and lazarette are both watertight. All other interior bulkheads and interior divisions are made of high spec marine plywood. All structural bulkheads are laminated to the hull and bonded to deck. Self-draining anchor chain locker laminated to the hull and composite bulkhead towards the interior, accommodating the standard 75m of 10mm galvanized chain.

SPECIFICATIONS

KEEL STRUCTURE & KEEL

Keel structure of welded and heat galvanised high strength steel, bolted to longitudinal solid GRP stringers. Keel fin made of cast iron attached to the keel structure by stainless steel keel bolts. Antimony hardened lead T- keel bulb attached to the cast iron fin by stainless steel bolts. Keel fin encapsulated in 1 layer of epoxy and faired to original templates, ready for antifouling.

MAST & RIGGING

Keel-stepped, high-performance mast from John Mast. 3-spreader fractional mast for maximum trimming potential. Anodised aluminium finish. Tapered mast head. Integrated sheave boxes for double main sail halyards and double head sail halyards for furling jib and inner forestay jib. Extra reinforced in the gooseneck, vang and deck area. Internally fitted conduit for masthead anchor light, engine steaming light and optional electronic mast equipment (mast head wind transducer, radar). Rod rigging. Shrouds in discontinued linkage design with bronze turnbuckles. Turnbuckles attached to chain plates at bulwark. Rod forestay (inside Harken furling headstay). Rod permanent backstay connected via a rod bridle to 2 hydraulic backstay tensioners, operated via a Push-button backstay tension control (electric) central pumpstation, for optimal tension control.

Please note that the images in this brochure may show optional features and equipment that are not included in the standard specification. Arcona Yachts AB reserves the right to vary or alter the specification without notice. V. 2024-01



"I had two good trials on the boat in largely Force 3 and 4 winds, using a mix of jib, Code 0 and gennaker on various angles and in some swell, and can confirm this is a design that backs up its looks and price tag with performance."

-Toby Hodges, Yachting World



345

385

415

435

465

50

seyachts.com

+44(0) 2380 457 770

info@seyachts.com

